

Lakeside Water & Building Services have introduced a new range of side stream filtration systems. Based on the successful low maintenance cyclone separation units the Lakeside range is ideal for use in any closed loop system such as heating and cooling where contamination from the original installation or as a result of operational factors may exist. Cyclone separators are particularly suited for the removal of rust and corrosion products that often accumulate in water circuits as well as sand and grit that can often be a problem in systems that are open to the elements. By removing these impurities the life of ancillary equipment such as pumps and valves can be increased and the risk of failure reduced.

How it Works

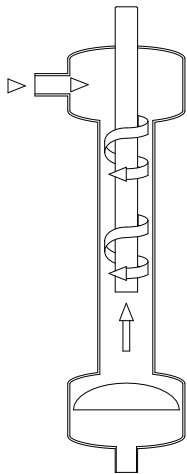

Water enters the unit tangential creating a centrifugal flow. The top section of the unit is designed to accelerate the centrifugal flow. The effective of the centrifugal force moves suspended solids to the side. Solids slowly drop along the sides until they reach the bottom chamber. The cleaned water is drawn up through the vortex into the central discharge pipe. The solids that have accumulated in the bottom chamber can be removed periodically through a purge valve to drain or continuously through secondary dirt filter and returned to the system.

The efficiency of the separators is dependent on a number of factors including, particle size, Specific gravity and the number of passes. Circulating systems are more efficient on smaller particles than a single pass as illustrated in the table below

Cyclone Separation Efficiency - Expected Separation %

Specific gravity of solids kg/dm ³	Particle size of solids					
	70µ		70 - 40µ		≤ 40µ	
	single	circulation	single	circulation	single	circulation
7.8	96	98	90	94	65	84
4.2	93	98	75	92	51	72
2.4	92	97	71	91	38	65
1.9	75	93	27	55	8	31

Lakeside offers a range of systems with flow rates from 2.5 - 35m³/hr. The size of the system should take into consideration the total system capacity and the flow rate. The recommended size will depend on the age and condition of the system. Generally the total system capacity should be filtered at least once every four hours with a target of between 2.5% and 10% of flow rate. If the capacity is not known we would recommend side stream filtration of between 5% and 10% of flow rate.

Models and Options

All systems are designed for use in closed circuit systems and operate by drawing water from the system through a booster pump that in turn pumps water through the cyclone separator before returning the water to the circuit. The purged water can either be sent to drain or returned to the circuit. Open impeller pumps are supplied to allow particles up to 6mm to be safely pumped to the separators.

Three options are available, the basic model LWB-PS is available in 6 sizes and is supplied without options. The LWB-AP models are supplied with an auto purge system as standard and have a BMS option available so that they may be controlled from the system pumps. The LWB-CF models are supplied with a dirt removal filter and are designed for use in closed circuit systems and give the advantage of no fluid loss. The BMS option is available with this system. In addition a filter warning is also available to indicate when the dirt filter requires changing. All systems are mounted on their own skid base and are supplied fully assembled ready for installation.

All systems are available with steel, ABS or PVC pipework to suit the application.

Maximum working temperature ABS or PVC: 60°C

Maximum working pressure ABS or PVC: 6 Bar

Maximum working temperature Steel: 90°C

Maximum working pressure Steel: 8 Bar

In addition to the standard ranges Lakeside can supply custom designed systems to suit our customer's requirements.

LWB-PS Systems

Manually controlled pumped system recommended where a basic system is required. The purge system is operated manually and therefore requires attendance on a regular basis, at least once per shift when operational. The purge is likely to require more frequent operation until the system has been cleaned to normal working levels. A small amount of water is lost each time the purge is operated.

Features

- Booster pump
- Starter with push buttons for start and stop
- Mild steel skid base with anti-vibration mounts
- Mild steel cyclone separator
- Pressure gauges
- Isolation valves
- Pipework in either mild steel, ABS or PVC

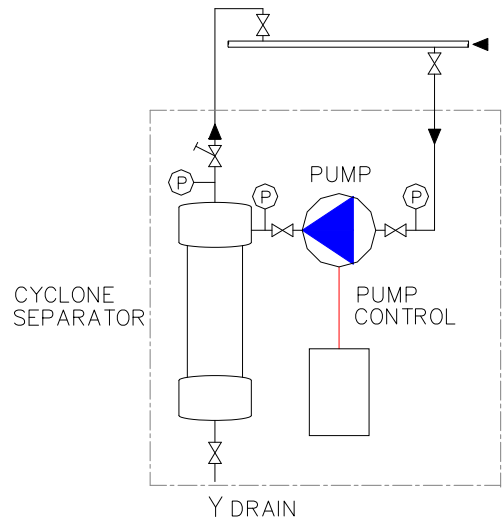

LWB-PS

Model	Flow (M ³ /hr)	Voltage/ KW	Inlet / Outlet Connections	Options Available
LWB-PS-20 /240	2.5 - 4.5	230 / 0.55	3/4" / 3/4"	None
LWB-PS-20 /400	2.5 - 4.5	400 / 0.55	3/4" / 3/4"	None
LWB-PS-25 /240	3.5 - 7.0	230 / 0.75	1" / 1"	None
LWB-PS-25 /400	3.5 - 7.0	230 / 0.75	1" / 1"	None
LWB-PS-32 /400	5.0 - 10.0	400 / 1.1	1 1/4" / 1 1/4"	None
LWB-PS-40 /400	8.0 - 18.0	400 / 2.2	1 1/2" / 1 1/2"	None
LWB-PS-50 /400	15.0 - 24.0	400 / 3.0	2" / 2"	None
LWB-PS-65 /400	20.0 - 35.0	400 / 4.0	2 1/2" / 2 1/2"	None

LWB-AP Systems

Auto purge system incorporates a solenoid controlled purge valve with timers for frequency of purge and purge time. The purge frequency can be reduced once the system is cleaned. A small amount of water is lost each time the purge is operated. The LWB-AP models are ideal for use in continuous use systems and are available with the BMS interface option.

Features

- Booster pump
- Starter with push buttons for start and stop
- Pump run and tripped LED lamps
- Purge valve open LED Lamp
- Auto / off / manual purge switch
- Mild steel skid base with anti-vibration mounts
- Mild steel cyclone separator
- Pressure gauges or flow indicator
- Set-up valve for flow adjustment
- Isolation valves
- Pipework in either mild steel, ABS or PVC
- BMS interface option available

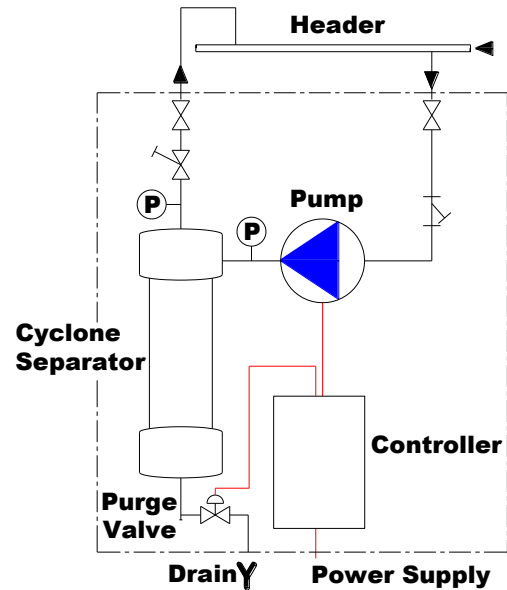

LWB-AP

Model	Flow (M ³ /hr)	Voltage/ KW	Inlet / Outlet Connections	Options Available
LWB-AP-20 /240	2.5 - 4.5	230 /0.55	3/4" / 3/4"	BMS Interface
LWB-AP-20 /400	2.5 - 4.5	400 /0.55	3/4" / 3/4"	BMS Interface
LWB-AP-25 /240	3.5 - 7.0	230 / 0.75	1" / 1"	BMS Interface
LWB-AP-25 /400	3.5 - 7.0	230 / 0.75	1" / 1"	BMS Interface
LWB-AP-32 /400	5.0 -10.0	400 / 1.1	1 1/4" / 1 1/4"	BMS Interface
LWB-AP-40 /400	8.0 -18.0	400 / 2.2	1 1/2" / 1 1/2"	BMS Interface
LWB-AP-50 /400	15.0 - 24.0	400 / 3.0	2" / 2"	BMS Interface
LWB-AP-65 /400	20.0 - 35.0	400 / 4.0	2 1/2" / 2 1/2"	BMS Interface

LWB-CF Systems.

Supplied with a secondary cartridge or bag filter dirt recovery system this model is ideal for systems where water loss through purging or the lack of suitable drainage is a problem. Unlike the other models the purge is continuous with the debris being collected in a bag filter. The LWB-CF models are available with the BMS interface.

Features

- Booster pump
- Starter with push buttons for start and stop
- Pump run and tripped LED lamps
- Stainless steel cartridge filter / dirt collector
- Mild steel skid base with anti-vibration mounts
- Mild steel cyclone separator
- Flow indicators or pressure gauges
- Set-up valves for system and purge flow
- Isolation valves
- Pipework in either mild steel, ABS or PVC
- BMS interface option available

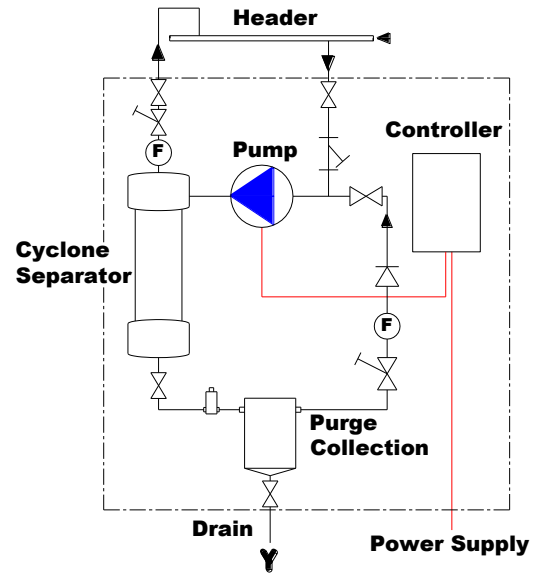

Model	Flow (M ³ /hr)	Voltage/ KW	Inlet / Outlet Connections	Options Available
LWB-CF-20 /240	2.5 - 4.5	230 /0.55	3/4" / 3/4"	BMS Interface
LWB-CF-20 /400	2.5 - 4.5	400 /0.55	3/4" / 3/4"	BMS Interface
LWB-CF-25 /240	3.5 - 7.0	230 / 0.75	1" / 1"	BMS Interface
LWB-CF-25 /400	3.5 - 7.0	230 / 0.75	1" / 1"	BMS Interface
LWB-CF-32 /400	5.0 -10.0	400 / 1.1	1 1/4" / 1 1/4"	BMS Interface
LWB-CF-40	8.0 -18.0	400 / 2.2	1 1/2" / 1 1/2"	BMS Interface
LWB-CF-50	15.0 - 24.0	400 / 3.0	2" / 2"	BMS Interface
LWB-CF-65	20.0 - 35.0	400 / 4.0	2 1/2" / 2 1/2"	BMS Interface

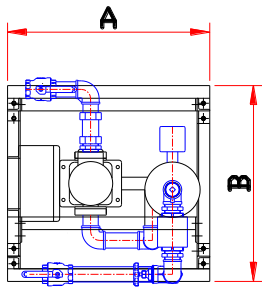

Model	A	B	C	D
LWB-20	600	560	1256	756
LWB-25	600	620	1256	756
LWB-32	700	710	1356	796
LWB-40	700	750	1356	796
LWB-50	800	775	1356	896
LWB-65	800	970	1536	896

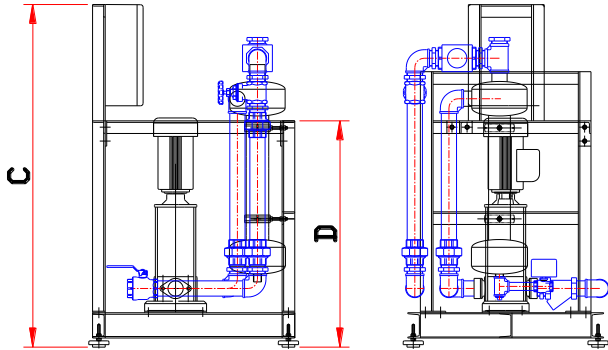

Above dimensions apply to LWB-PS and LWB-AB models.

Dimensions are approximate and are dependent on pipework material. Pipework configuration is dependant on model

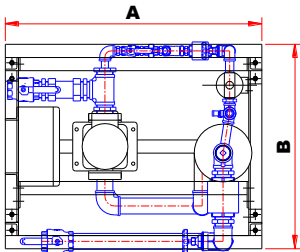

Model	A	B	C	D
LWB-CF-20	900	625	1256	1096
LWB-CF-25	900	675	1256	1096
LWB-CF-32	900	710	1356	1096
LWB-CF-40	900	750	1356	1096
LWB-CF-50	975	775	1356	1096
LWB-CF-65	1060	935	1536	1136

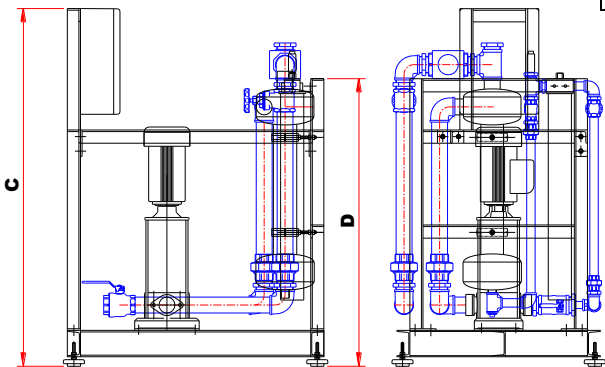

Dimensions are approximate and are dependent on pipework material.

Pipework configuration is dependant on model